

## MODEL DB32

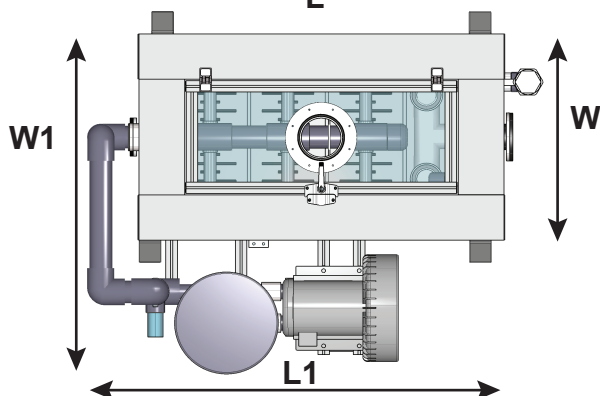

L = 4 ft - 8 3/8 in; L1 = 5 ft - 11 in  
W = 2 ft - 8 3/8 in; W1 = 4 ft - 6 in  
H = 6 ft - 1 in

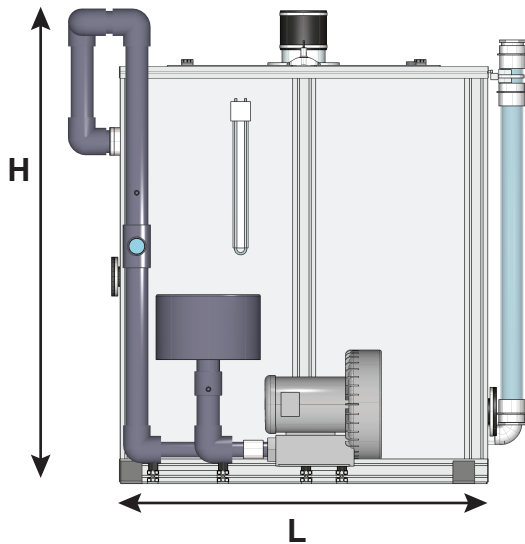

# DEEPBUBBLE™ Multi-Stage Air Stripper

- HDPE VESSEL & MODULAR ALUMINUM FRAME
- INSULATED NO-SWEAT TANK
- HIGH-EFFICIENCY
- LOW MAINTENANCE

Number of Stages	3
Max Flow, gpm	150
Max Air, scfm	200
Inlet & Outlet Size	2" to 6" exp flange
Vent	6"
Empty (shipping) Weight, lb	525 (vessel only)
Operating Weight, lb	1,950 (vessel operating)
Blower & Filter, lb	150

NOTE: specifications subject to change without notice

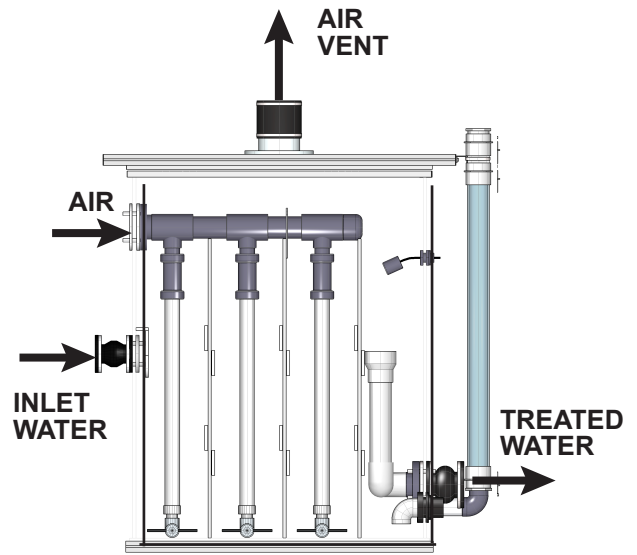

*Maximum water flow allowed is determined by the Air:Water Ratio required for treatment goal*

**Designs & Quotations  
CALL 800 - 434 - 9080**

[www.lowryh2o.com](http://www.lowryh2o.com)

DEEPBUBBLE Multi-Stage Aeration Systems are furnished complete with blower, filter/silencer, and accessories with Lowry Aeration Systems' guarantee of performance. Optional control panels and booster pumps available.